

**money machine** \ *n* \ : a CAMAS separator if you have visual scab in durum or wheat, or vomitoxin infected soft white wheat or barley.

*The patented CAMAS specific gravity separator removes diseased kernels and increases test weight, adding as much as \$1 or more pure profit to the value of a bushel of your crop!*

**CAMAS separator FEATURES:**

- **REMOVES** a high percentage of DON and almost all of the visual damage in durum or wheat.
- **Substantially reduces Vom levels** in barley.
- **Rejects FAR LESS** good grain than other methods.
- **HIGHER CAPACITIES THAN ANYTHING IN ITS CLASS—FROM 500 UP TO 5000 BUSHELS PER HOUR.** (capacity varies by model)
- **Cleans out all sorts of dockage problems.**
- **Minimal change-over and set-up for different crops.**
- **NO awkward screens to maintain or replace.**
- **Very economical operation.**
- **Available in either stationary or mobile configurations.**
- **May replace several pieces of equipment in a cleaning line.**



Product "stream" showing high speed separation of contaminants, including ergot and various weed seeds.



***CAMAS increases your profits!***

Growers are finding Camas separators to be indispensable "value added" machines—adding value to their crop. As dockage penalties increase, it makes more and more sense for the grower to clean his own commodities and increase cash flow. For special problems such as insect damage, scab in wheat or durum, or vomitoxin in barley or white wheat, the Camas can add a dollar or more per bushel profit. *The Camas can easily make the difference between a year of profit or loss.*

Based upon modern principles of fluidized bed technology, the Camas separator sets new standards for precision, efficiency, capacity, dependability and thus: profitability. Using air flow and vibration, the Camas separator actually suspends the product and turns it into what appears as a "dry liquid". Damaged, diseased, and underdeveloped kernels, weed seeds, and light contaminants float to the top and are easily removed from the "stream". For heavy contaminants, a destoner may be included in the machine. Camas owners call the optional Camas destoner, "the best in the world." Its effectiveness for heavy impurity removal exceeds 99%.

A traditional gravity table requires a 13% density difference to be effective. The Camas separator operates on differences as small as two percent! The two percent difference is sensitive enough to remove mycotoxin infected kernels from healthy grain. It's been proven on many other commodities other than all small grains. In fact, there's a good chance the cocoa beans used to make the chocolate bar you had for lunch were processed by a Camas.

### SV4-8

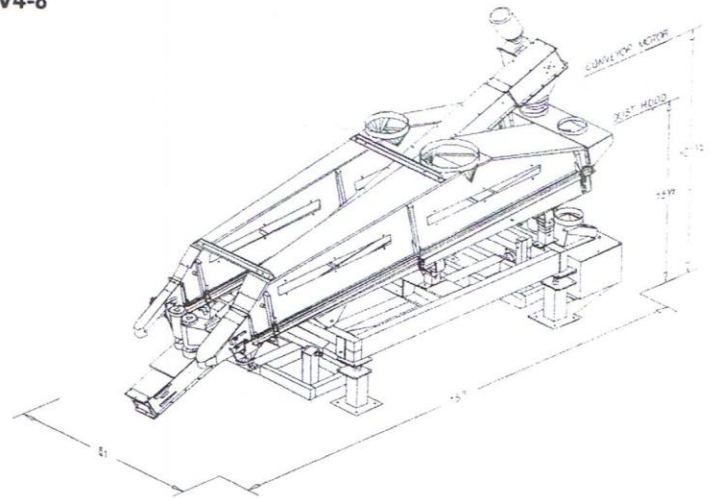
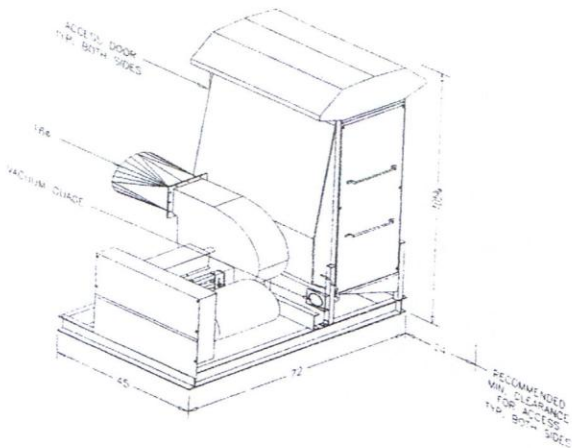

## WEIGHTS AND DIMENSIONS

### Blower:

Weight: 1,200 lbs  
 Height: 105 5/8 inches  
 Length: 72 inches  
 Width: 45 inches

### Separator:

4,200 lbs  
 72 1/2 inches  
 143 1/2 inches  
 60 5/8 inches

**Note :** Above specifications are for the most popular model SV4-8F. Specifications for other models will vary. Some features shown may be extra cost options. Also, specifications are subject to change without notice.



**Mike Bergstrom**

~ Specialty Equipment Sales & Consultant ~

304 Skyline Dr NE ~ Great Falls, MT 59404  
 Cell 406.240.0069 ~ Fax 406.403.0385  
[MikeB@Mill-Mac.com](mailto:MikeB@Mill-Mac.com) ~ [www.Mill-Mac.com](http://www.Mill-Mac.com)