

Mid-Range Air Screen

. . . Mid-range machine with Industrial Quality

Manufactured in the U.S.A.

Standard Features

Gentle vibratory feeder for 0% crop damage

Aggressive design enables handling of rough materials

All standard bearings and replacement parts

Large air settling chambers for even & accurate air separation

Low HP requirements, 1/2 HP on machine and 3 HP on fan

Large selection of screens available: from 27 sq. feet of screen area

Screens available in all steel construction

2-air separations

Screening collection Spout

110 or 220 Volts

Designed and built by seeds men



Modular Design Advantages

Low Cost initial investment

Basic units have the same heavy duty construction as the larger units

Very low maintenance

Screen can be replaced easily for different types of product cleaning

Modules for air separation, metering feed and additional screen area

Custom Options Available

Cleaned Product Shoot Dust Solution System

Intake Hopper Extension

Scalper Feeder ~ Product Screens



P.O. Box 3167 ~ Great Falls, MT 59403

Phone ~ 406.727.6514 ~ Toll ~ 1.800.977.6514

Web site ~ www.benchindustries.com ~ E-mail ~ brian@benchindustries.com

Flow Diagram

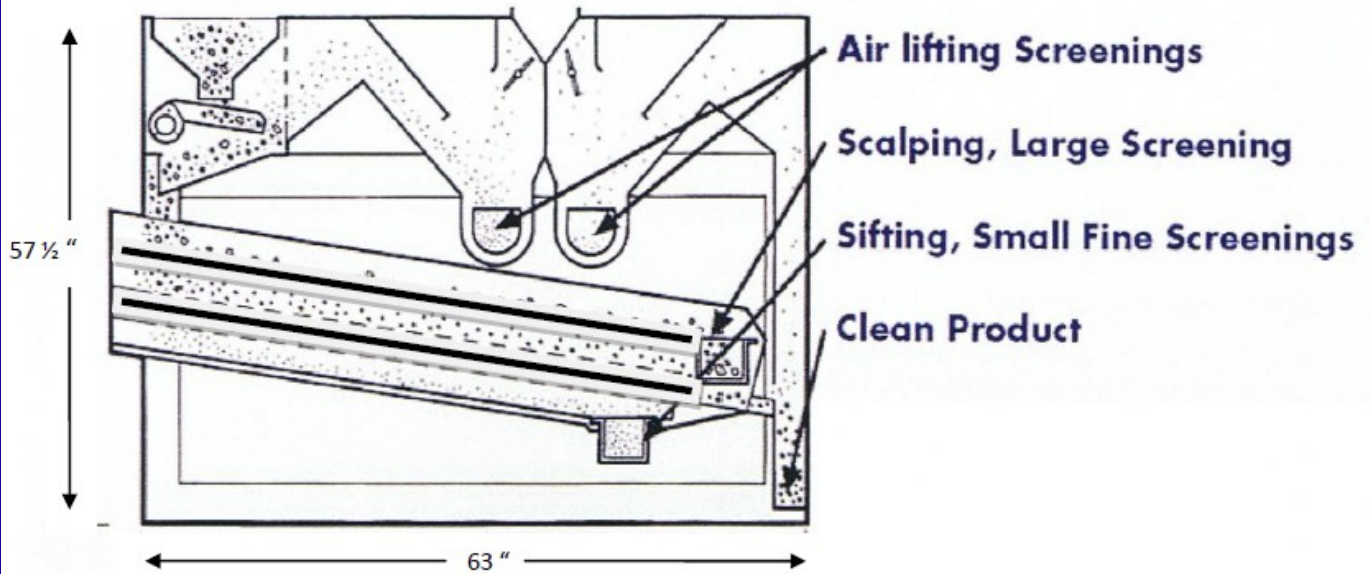

Specifications

Pre-Cleaning Capacity.....500 Bu
 Seed Cleaning Capacity.....200 Bu
 Screen Area.....27 Sq Ft

Power Requirements

Fan3 hp
 Shoe...1/2 hp
 Air Volume ...up to 5000 cfm
 Shipping Weight.....1780 lbs

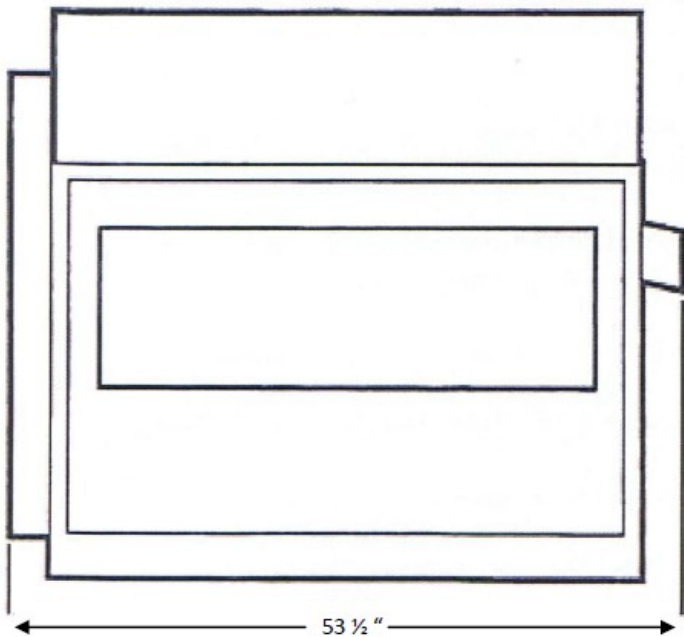

Capacities will vary on type of product
 and foreign material to be removed